

---

# **CLEMENTS**

---

proven through performance

## ***Thoracic*** **Very Low Vacuum High Flow** **Suction Pump** SUC 84154



### **User Manual**

Manual No. SUC 84154 016  
Issue 25

---

## **Safety**

Thank you for purchasing this Clements Thoracic Low Suction Pump.

For your safety it is imperative that this unit only be operated by authorised personnel in accordance with the instructions as described in this manual. Operated in this way, the Thoracic Low Suction Pump will provide the standard of service specified.

Due to continual improvements in product design, the Thoracic Low Suction Pump may vary in detail from the descriptions in this manual. In the event of further questions please contact your local distributor or BMDi TUTA Healthcare direct.

User Manual  
Thoracic Low Suction Pump  
Manual Number SUC 84154 016 Issue 25

Copyright © 2015 BMDi TUTA Healthcare Pty Ltd

The information in this manual was originated by, and is the exclusive property of BMDi TUTA Healthcare Pty Ltd. It is furnished for customer information only, and is not an authorisation or licence to make this product or to furnish this information to others.



**BMDi TUTA Healthcare Pty Ltd**  
**Unit 4B, 128-130 Frances Street**  
**Lidcombe NSW 2141 Australia**  
**Phone: +61 2 9466 5300**  
**Website: [www.medaust.com](http://www.medaust.com)**

**Contents**

<i>Classifications .....</i>	<i>4</i>
<i>Specifications .....</i>	<i>5</i>
<i>Transportation and Storage .....</i>	<i>6</i>
<i>Description .....</i>	<i>8</i>
<i>Installation and Operation .....</i>	<i>9</i>
<i>Operation - Reusable Jar .....</i>	<i>10</i>
<i>Operation - Reusable Jar .....</i>	<i>11</i>
<i>Spares .....</i>	<i>16</i>
<i>Maintenance .....</i>	<i>18</i>
<i>Troubleshooting .....</i>	<i>20</i>
<i>Diagnostic Setup .....</i>	<i>22</i>
<i>Disassembly and Repair .....</i>	<i>24</i>
<i>Emissions Guidance Table 201 .....</i>	<i>26</i>
<i>Immunity Guidance Table 202 .....</i>	<i>27</i>
<i>Immunity Guidance Table 204 .....</i>	<i>28</i>
<i>Warranty .....</i>	<i>30</i>

**Identification**

SUC 84154 Thoracic Low Vacuum / High Flow Suction Pump

**Intended Use**

To provide a continuous vacuum source, within the stated operating vacuum range, for the aspiration of fluids and particulate matter in medical procedures carried out by clinically trained and authorized personnel.

**Uninterrupted Availability**

This equipment is mains powered. If patient care requires the uninterrupted availability of a source of vacuum, the clinical facility must make provision for either a backup power supply or standby suction units which are battery or manually powered.

<b>Classifications</b>	
GMDNS Code	36787
GMDNS Term	Suction Unit, Thoracic
GMDNS Synonym	Aspirator
Device Class	Class IIa
Electric Shock Protection	Class I Equipment
Additional Electric Shock Protection	Defibrillation-proof Type BF Applied Part
Sterilisation	Not supplied in sterile state
Anaesthetic Rating	NOT Category AP NOT Category APG
Operation Mode	Continuous operation

---

## Specifications

### Thoracic SUC 84154

Power Rating	220 - 240 V 50/60Hz 380W
Vacuum Range	0 to -7 kPa 0 to -70 cm H <sub>2</sub> O
Max Flow Rate	20 litre / min (through jar)
Motor	Thermally protected PSC motor
Pump	Oil Less twin piston
Ambient Requirement	Continuous operation in ambient temperatures of 5°C to 35°C.
Filters	Inlet: disposable bacteria filter Exhaust: clean, bleached cotton wool (5g) Internal: disposable hydrophobic filter
Reusable Collection Jars (Optional)	2 x 2 litre autoclavable, shatter resistant polycarbonate jars with non-static polypropylene bungs and overflow shut-off valves.
Disposable Collection Jars (Optional)	2 x 3 litre disposable liner with reusable support jars Liner incorporates hydrophobic and antibacterial filter
Regulator	Needle Valve
Gauge	Bourdon tube type Dual Scale, mm Hg / kPa. Accuracy ±3% FSD
Gauge Range	0 to -8 kPa graduated at 0.2 kPa 0 to -80 cm H <sub>2</sub> O graduated at 2 cm H <sub>2</sub> O
Unit Dimensions	Width 406mm, Depth 305mm, Height 800mm Weight 16.5kg
Standard Conditions	25°C, Sea Level, 100kPa
Environment	Indoor

## Transportation and Storage

Environmental conditions for transportation and storage are shown in the following table. In addition, for vehicular transportation, the unit should be packed in its original packaging and kept upright.

Parameter	Minimum	Maximum
Temperature	10°C	40°C
Humidity	60% RH	95% RH
Barometric Pressure	700 mBar	1060 mBar

## Warning Symbols Legend

The warning symbols marked on the equipment and their meanings are shown as follows.



**Attention, consult accompanying documents**

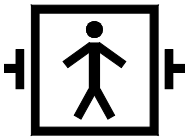

**Defibrillation-Proof Type BF applied part**



**Dispose of product according to requirements of WEEE directive**

## **Electromagnetic Interference**

This equipment generates, uses and can radiate radio frequency energy and, if not installed and used in accordance with the instructions, may cause harmful interference to radio communications. However, there is no guarantee that interference will not occur in a particular installation. If this equipment does cause harmful interference to radio or television reception, which can be determined by turning the equipment off and on, the user is encouraged to try to correct the interference by one or more of the following measures:

- Reorient or relocate the receiving antenna.
- Increase the separation between the equipment and the receiver.
- Connect the equipment into an outlet on a circuit different from that to which the receiver is connected.
- Consult the dealer or an experienced radio/TV technician for his or her help.

Changes or modifications to the equipment not expressly approved by Clements could void the user's authority to operate the equipment.

## Description

The Clements Thoracic Low Suction Pump is a mobile, enclosed suction pump designed for low suction and high flow.

The main feature of this unit is the low maintenance piston motor and pump assembly which can generate suction strengths from 0 to  $-70 \text{ cm H}_2\text{O}$  ( $-7 \text{ kPa}$ ) with flow rates up to 20 litres of Free Air Per Minute (FAPM), depending on the model and power supply.

The unit is mounted on large rubber wheels which make it easy to move to any part of a hospital. The unit also has a storage compartment at the rear to house additional tubing, handpieces and other items needed when using the pump.

### Main Components of Unit

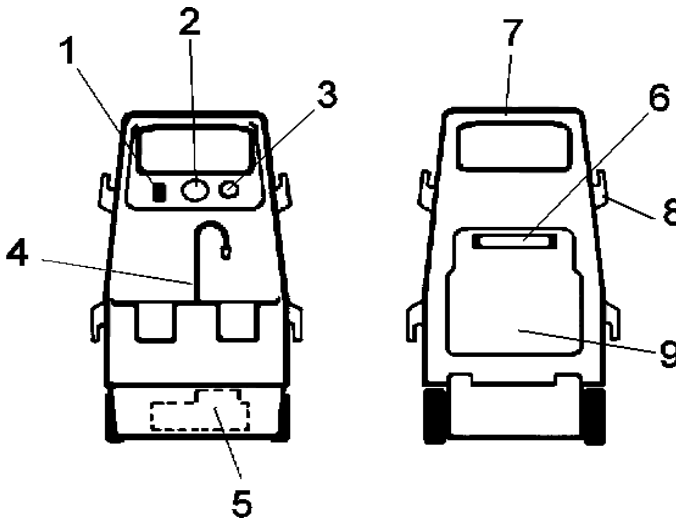

1	Power Switch	6	Exhaust Filter
2	Vacuum Gauge	7	Handle
3	Regulator Control Knob	8	Tube Storage Hooks
4	Inlet Connection	9	Storage Compartment
5	Pump (Internal)		



## Installation and Operation

### Contents

<b>SUC 84154</b>	
SUC 84154 Thoracic Suction Pump	
Power lead, User Manual	
<b>SUC 84154 012</b>	<b>SUC 84500 130</b>
2 x 2L Reusable Collection Jar with Bung Assembly. (One with Underwater Drainage Tube)	2 x 3L Disposable Liner with Reusable Support Jars and Ring Brackets
2m + 0.3m Yellow Suction Tubing	2m Yellow Suction Tubing
Blue Antibacterial Filter and Nipple	0.3m Silicone Tubing and Nipples

### Important

Remove transportation strapping from motor before starting. Ensure power is disconnected before opening unit.

#### **WARNING**

**This unit generates low vacuum. It must not be used for emergency applications which require high vacuum.**

**Always check patient requirements before applying the Clements Thoracic Low Suction Pump.**

### Connecting The Collection Jars

The unit is fitted with two Collection Jars and can be connected either in a single-jar arrangement or a double-jar (cascade) arrangement.

With the single-jar arrangement, only one jar is in use at a time, with the second jar on standby. As one jar is filled it is disconnected, so that it can be emptied, and the other jar is connected.

The double-jar arrangement allows both jars to be in use at the same time, thus providing longer periods between changeover. However, the larger volume means the vacuum pull-down time is longer. Performance is generally better in a single jar setup.

**Single-Jar Arrangement—2L Reusable Jar**

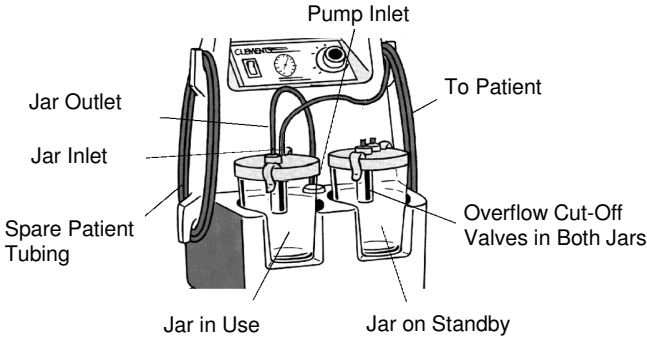

To connect the Collection Jars in a single-jar arrangement, use the following procedure and refer to the block diagram below.

1. Place two clean jars in the holders, ensuring that both jars are fitted with an Overflow Cut Off Valve. (Note orientation)
2. Connect the SUCTION outlet of the jar to be used first to the Bacteria Filter inlet on the main unit.
3. Connect the PATIENT inlet of the jar to be used first to the Suction Tube leading to the patient.
4. When the first jar is full, disconnect it and use steps 2 and 3 to connect the second jar.

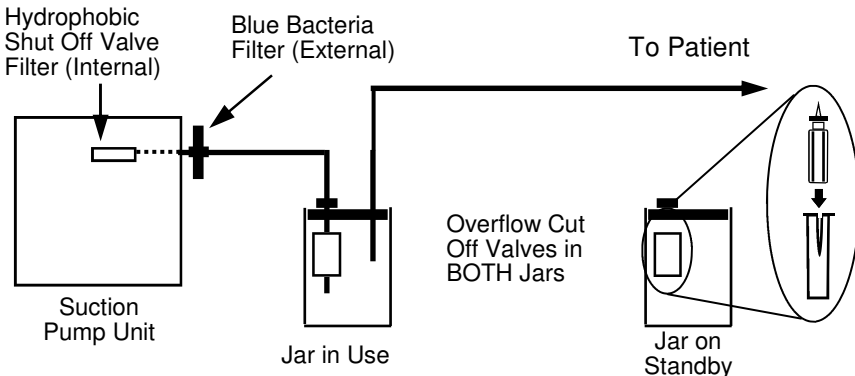

**Double-Jar Arrangement—2L Reusable Jar**

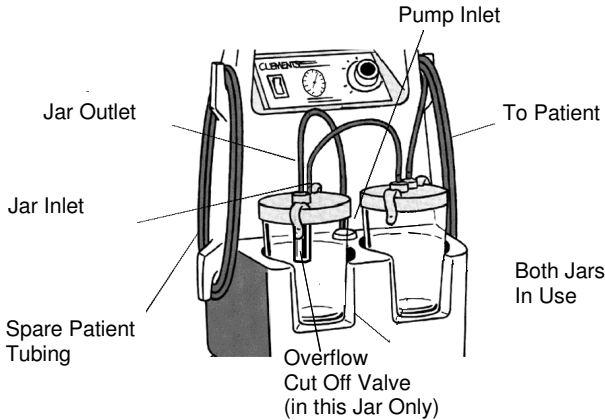

To connect the Collection Jars in a double-jar arrangement, use the following procedure and refer to the block diagram below.

1. Place two clean jars in the holders, ensuring that only one jar, Jar 1, is fitted with an Overflow Cut Off Valve.
2. Connect the SUCTION outlet (with the Overflow Cut Off Valve) of Jar 1 to the Bacteria Filter inlet on the main unit.
3. Connect the PATIENT inlet of Jar 1 to the SUCTION outlet of the jar without an Overflow Cut Off Valve, Jar 2.
4. Connect the PATIENT inlet of Jar 2 to the Suction Tube leading to the patient.

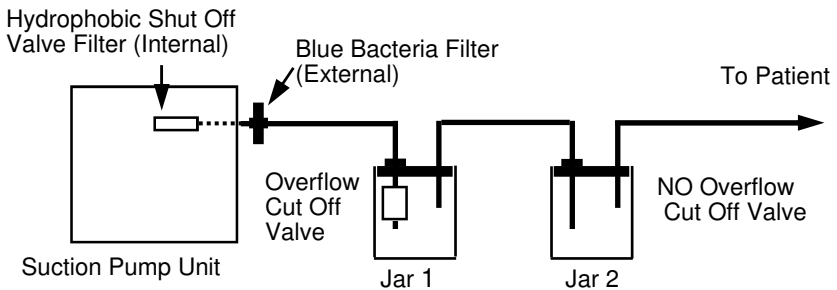

## Operation

To operate the Pump, follow the steps listed below.

1. Place the pump on a level surface with a 15cm clearance from walls or other objects.
2. Install the Collection Jars and Suction Tubing in either the single-jar or double-jar arrangement as described in the *Connecting The Collection Jars* section.
3. Connect the unit to the mains power supply and switch the power on at the mains supply outlet.
4. Press the Power Switch down into the 'I' (ON) position and the Motor will run.
5. Occlude the Suction Tubing and adjust the Regulator, by turning the knob, to obtain the required vacuum level, as indicated on the Vacuum Gauge.
6. Check that there is no loss of vacuum in the Suction Tubing and fittings.
7. Apply the catheter to the patient.
8. Check the Collection Jars to ensure that suction is being applied correctly.

### **Please Note:**

- Although the Collection Jars are fitted with Overflow Cut Off Valves, the fluid levels should be monitored to prevent spill-over into the pump unit. The Hydrophobic Filter fitted to the inlet of the pump acts as a single use shut-off valve to protect the pump. It must be replaced if fluid has spilled over into the pump unit.
- Always start the pump with Suction Tubing unoccluded. Always clear any blockages before re-starting the pump.
- The pump motor is protected by a thermal overload mechanism that will stop the pump if the temperature exceeds a pre-set level. The mechanism will then automatically restart the Pump after the motor has cooled to the appropriate temperature.

If the motor thermal overload trips, switch the power off at the mains switch. This will prevent unexpected re-starting of the pump when the thermal overload automatically resets upon cooling.

- If it is suspected that fluid may have entered the pump, either by an external spill or by a jar overflow, the unit must be taken out of service until the fault has been fixed and its continued electrical safety has been confirmed. The service department must also be notified of any potential biohazard.

## Single-Jar Arrangement—3L Disposable Liner Jar

### Setup

1. Insert liner bag [1] into the matching size support jar [2]. Press edge of lid firmly all around edge to ensure seal.
2. Close the TANDEM inlet [3] with the attached cap [4].
3. Fit jar assembly into ring bracket.
4. Fit blue nipple of the connector tubing to blue pump inlet nipple [8].
5. Press yellow nipple of connector tubing firmly into matching yellow port [5] on the lid.
6. Connect patient tubing to white inlet elbow [7]. Connect patient tubing to suitable suction cannula.



Note: For disposable jars only, which have an antibacterial filter built-in to the lid, connection may be made directly to the pump inlet nipple.

For reusable jars, connection must be made through an inline blue antibacterial filter.

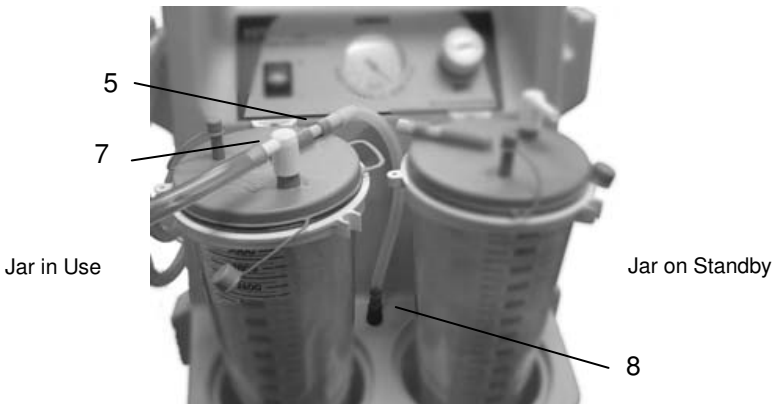

**Operation**

1. Turn on power switch.
2. Occlude suction cannula and adjust vacuum control to obtain the required vacuum level.
3. Check that there is no loss of vacuum in the Suction Tubing and fittings.
4. Apply the catheter to the patient.
5. Check the Collection Jars to ensure that suction is being applied correctly.

If fluid reaches the maximum level the hydrophobic filter in the lid will operate to prevent further fluid flow. When this happens switch off pump.

**Disposal**

1. Switch off pump.
2. Disconnect tubing from jar.
3. Remove the white elbow [7] and close the inlet port with the cap [9] attached to lid.
4. Using the lid handle remove the liner [1] from the support jar and dispose of liner according to hospital protocol.
5. Retain support jar [2] for reuse.

**Support Jar Cleaning**

The reusable support jar may be cleaned either with water and neutral detergents or autoclaved at 121°C for 15 minutes.

Do not use solvents or alcohol for cleaning and disinfection. These may damage the support jar.

The mechanical integrity of the support jar is guaranteed for 30 cleaning cycles under the specified conditions.

After this, the jar may show signs of wear and replacement is recommended.

**Spares**

MUL 94004 000	Mains Power Switch Green Rocker
SUC 37043	Cotton Wool for Suction Pumps Exhaust Filter
SUC 80254	Very Low Vacuum Gauge 0 to -8kPa [80 cm H <sub>2</sub> O]
SUC 80297 001	Kit Yellow Suction Tubing (20 metre Roll)
SUC 80301	2 litre Collection Jar for Suction Pumps (Jar Only)
SUC 80323	Bung Assembly with Underwater Drainage Tube for 2L Collection Jar
SUC 80404 001	Single Use Plastic Handpiece (Pack 10)
SUC 81409 888	Kit, Fuse for HiVac Pump (Pack 10)
SUC 84100 049	Exhaust Filter Assembly for Suction Pumps
SUC 84100 109	Kit, Exhaust Filter Silencer (Pack 5)
SUC 84100 162	Filter, Bacteria (Pack 12)
SUC 84100 405	Hydrophobic Shut-Off Valve Filter (Pack 5)
SUC 84100 505	Footswitch Kit for Suction Pumps with (Switch, Pneumatic Actuator)
SUC 84100 121	Resilient Motor Mount (Pack 4)
SUC 84101 012	Kit, 2L Reusable Collection Jar (Pack 2)
SUC 84112 004	Motor and Pump for HiFlo / Neonatal / Thoracic
SUC 84200 033	Bung Assembly with Overflow Cut Off Valve for 2 litre Collection Jar
SUC 84200 501	Seal for Collection Jar Bung (Pack 2)



---

**Spares**

SUC 84200 502	Suction Inlet Nipple for 2 litre Jar Bung (Pack 4)
SUC 84200 503	Kit Grey Bung Float Chamber (Pack 2)
SUC 84200 518	Washer for Overflow Valve (Pack 4)
SUC 84200 519	Blue Male Nipple for Bacteria Filter (Pack 10)
SUC 84200 520	Blue Female Nipple for Bacteria Filter (Pack 10)
SUC 84500 110	Kit, Mounting for 3L Disposable Jar (Pack 2)
SUC 84500 111	Kit, Jar Connect Tubing (Pack 2)
SUC 84500 112	Kit, Liner Connect Nipple (Pack 5)
SUC 84500 113	Kit, Ring Bracket for 2L/3L Disposable Jar (Pack 2)
SUC 84500 120	Kit, Support Jar for 3L Disposable Liner (Pack 2)
SUC 84500 123	Kit, Disposable 3L Liner (Pack 50)
SUC 84500 130	Kit, Starter, 3L Disposable Jar (Pack 2)
SUC 89107	Kit for Pump Vacuum Controller (Needle Valve Type)
SUC 89240 069	Regulator Knob Replacement Kit for Suction Pumps (Regulator Knob, Screw)
SUC 84154 016	User Manual for the Thoracic Low Suction Pump

## Maintenance

**IMPORTANT**

**There are no user-serviceable components inside.  
Maintenance must be carried out by qualified  
personnel only.**

To keep your Clements Thoracic High Suction Pump in good condition, the following maintenance is recommended.

### After Each Operation

- **Blue Bacterial Filter**

The blue bacterial filter is an important device to help protect the pump from moisture and bacteria taken from patient airways. Clements recommend that the filter be changed every month or when the unit is used on infectious patients or when damp or discoloured.

- **Housing**

Wipe clean with a damp soapy cloth. Do not immerse or allow liquid to enter the housing.

- **Suction Tubing**

Suction Tubing should be sterilised with sterilants determined by local protocols and compatible with PVC tubing. Suction Tubing may be autoclaved to a maximum of 121°C for 20 minutes. At higher temperatures the Suction Tubing will discolour and lose shape.

- **Reusable Collection Jars**

Place jars upright or up-side-down in autoclave: **not on their sides**. Autoclave to a maximum of 136°C for 10 minutes. Do not use phenolic solutions as disinfecting agents in polycarbonate jars.

- **Bung**

Disconnect float cage and float from Bung. Place all items upright or up-side-down in autoclave - **not on their sides**. Autoclave all items to a maximum of 136°C for 10 minutes.

**Note:** Do not use abrasive cleaning agents as this may damage plastic surfaces and reduce the expected performance of an item.

## **After Every 100 Hours or 2 Months of Operation**

- Replace the Exhaust Filter:
  1. Remove the Exhaust Filter from the rear of the unit.
  2. Unscrew the caps and replace the cotton wool. The filter takes 5 gram of bleached and teased-out cotton wool.
- Check all Suction Tubing and replace if it is perished, soft or discoloured. Also check the tubing nipples.
- Check the seal rings on the Bungs and replace them if they are hard, cracked or perished. Check the fit of the Bung in the Collection Jar.
- Check the Overflow Cut Off Valve seals and replace them if they are perished or damaged.

### **IMPORTANT**

**The preceding maintenance should also be carried out immediately after use with infectious patients.**

## **Disposal and Recycling**

### **Waste Materials**

The contents of the collection jars, suction tubing, bacteria filter, internal hydrophobic shut-off filter, or the cotton wool in the exhaust filter may contain biohazard wastes. Handle using safe handling procedures, which may include the use of rubber gloves and eye protection, and dispose of according to local protocols for biohazard materials.



### **Recycling**

At the end of their service life, the pump and accessories should be dismantled if necessary, and disposed of according to the WEEE directive.

## Troubleshooting

<b>Fault</b>	<b>Check</b>	<b>Rectify</b>
No Suction But Motor is Working	Tubing Blocked	Clear or Replace
	Overflow Cut Off Valve Closed	Clear, Replace or Empty Jar
	Hydrophobic Shut –Off Valve Filter Blocked	Replace Hydrophobic Shut-Off Valve Filter
	Hydrophobic filter in lid of liner blocked	Replace liner
	Inlet Blocked	Clear
	Vacuum Gauge Defective	Replace Vacuum Gauge
	Regulator Blocked	Clear or Replace
	Bung Not Sealing	Adjust or Fit New Seal
	Regulator at Zero	Adjust Setting
No Suction: Motor Not Working	Mains Fuse Blown	Replace
	Faulty Mains Power Lead	Replace
	Power Not Turned On	Turn On
	Unit Fuses Blown	Replace
	Thermal Overload Activated	Wait For Unit To Cool Down
No Suction But Humming Can Be Heard From Motor	Blockage In Pump	Dismantle And Clean Pump
	Motor Windings	Replace Motor

<b>Fault</b>	<b>Check</b>	<b>Rectify</b>
Not Enough Suction	Regulator Setting Too	Adjust To Correct
	Leaks In Tubing or Fittings	Tighten Connections
	Blockage In Tubing or Fittings	Clear or Replace
	Hydrophobic ShutOff Valve Filter Blocked	Replace Hydrophobic Shut-Off Valve Filter
	Hydrophobic filter in lid of liner partially blocked	Replace liner
Excessive Noise Coming From Pump	Pump Worn	Replace Pump
	Pump Incorrectly	Assemble Correctly
Pump Runs Intermittently	Thermal Overload Is Cutting In and Out	Disconnect Mains Power And Wait For Unit To Cool Down

**Replacing the Hydrophobic Shut Off Valve Filter**

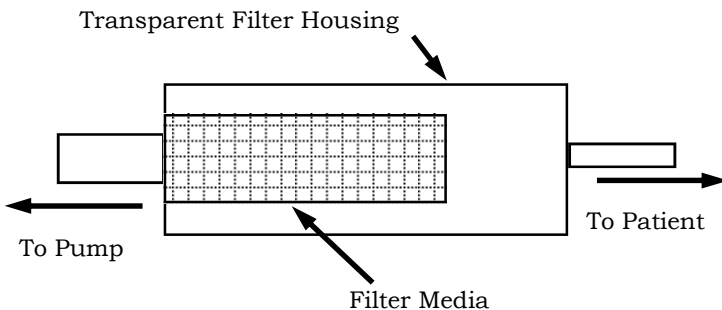

To ensure there is no entry of fluid into the pump the Hydrophobic Shut Off Valve Filter MUST be fitted as shown above.

---

## Setup for Diagnostic and Performance Testing

Note that the following arrangements are not used for actual suctioning applications. They are specified to remove unnecessary variations when diagnosing faults and as a standard setup for performance measurement.

### Vacuum Check

#### 1. Unoccluded - zero check

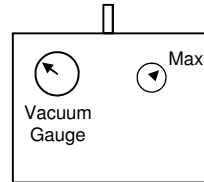

Disconnect all items from inlet and with pump switched off, confirm that gauge reads zero. A non-zero reading indicates a faulty gauge.

Set vacuum control knob to maximum, switch on pump and confirm that gauge reads zero. A non-zero reading indicates obstruction in internal tubing or connections.

#### 2. Occluded - vacuum check

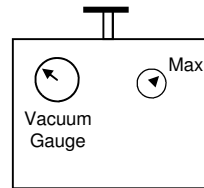

Switch on pump and occlude inlet. Note maximum vacuum reading.

#### 3. Occluded - gauge check

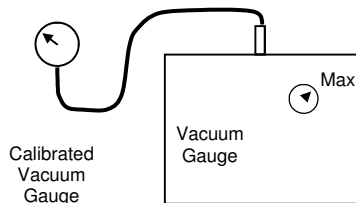

Connect a calibrated vacuum gauge directly to inlet and repeat maximum vacuum reading.

Confirm that pump gauge reads within the specified tolerance.

## Flow Check

### 1. Occluded - leak check

Jar: SUC 81099 (1 litre)  
or SUC 80312 (2 litre)  
Tubing: SUC 80297 (8x13mm)

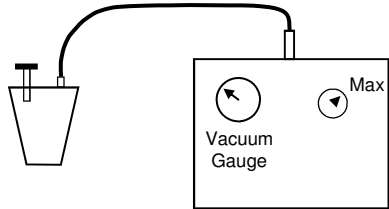

Connect pump as shown in diagram. Set vacuum control knob to maximum, and switch on pump. Occlude jar inlet and confirm that pump achieves the same maximum vacuum as in the previous vacuum check setup. Any difference indicates leaks in jar or connections.

### 2. Unoccluded - flow check

Jar: SUC 81099 (1 litre)  
or SUC 80312 (2 litre)  
Tubing: SUC 80297 (8x13mm)

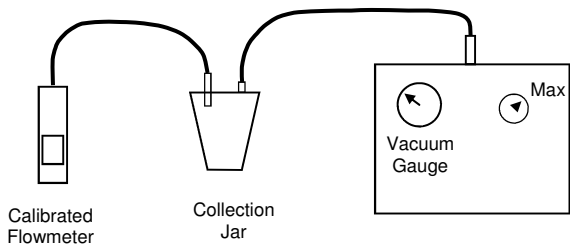

Connect pump as shown in diagram. Set vacuum control knob to maximum, and switch on pump. Connect jar inlet to calibrated flow meter and note flow reading. If flow is significantly below specification, check internal tubing and pump itself (or internal shutoff valve if fitted).

## **Disassembly and Repair**

### **Dismantling The Pump**

The steps for dismantling the Pump are as follows.

1. Disconnect the unit from the mains power supply.
2. Remove Collection Jars and Suction Tubing.
3. Remove the 4 screws from the base plate tabs at the rear of the unit and push the housing forward off the base plate.
4. Remove the four cylinder head screws from each head. Remove the cylinder heads.
5. Check O-ring, pistons and replace if worn, cracked or perished.
6. Clean the inside of the cylinder head. Check flapper valves and replace if worn, cracked or perished.
7. Reassemble pump.

### **Periodic Safety Check**

*The following safety checks should be performed at least every 24 months by a qualified person who has adequate training, knowledge, and practical experience to perform these tests.*

*\* Inspect the equipment and accessories for mechanical and functional damage.*

*\* Inspect the safety relevant labels for legibility.*

*\* Inspect the fuse to verify compliance with rated current and breaking characteristics.*

*\* Verify that the device functions properly as described in the instructions for use.*

*\* Test the protection earth resistance according IEC 60601-1: Limit 0.2 ohm.*

*\* Test the earth leakage current according IEC 60601-1: Limit: NC 500  $\mu$ A, SFC 1000 $\mu$ A.*

*The leakage current should never exceed the limit. The data should be recorded in an equipment log. If the device is not functioning properly or fails any of the above tests, the device has to be repaired.*



## Fuse Replacement

The Pump is fitted with two cartridge fuses located in fuse holders that are accessible from outside the unit. To replace the fuses use the following procedure.

1. Disconnect the unit from the mains power supply.
2. Locate the two fuse holders which are mounted on the rear side of the unit at the lower right-hand side.
3. Lift off the fuse holder cover.
4. Remove the old fuses and inspect them. If they are blown, replace them with new fuses.
5. Replace the fuse holder cover.
6. Connect the unit to the mains power supply, switch the power on, and ensure that the unit is operating correctly.

## Electrical Wiring Diagram

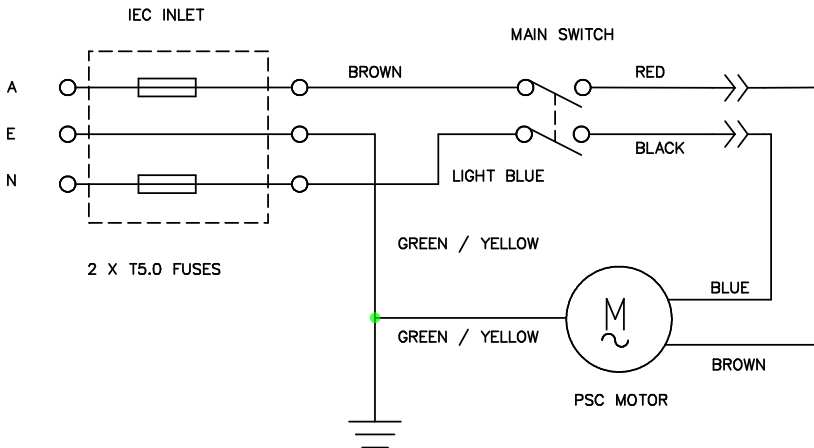

**EMC Information Tables per EN60601-1-2:2001-09 Section 6.**

In accordance with EN 60601-1-2:2001 Medical electrical equipment - Part 1-2: General requirements for safety - Collateral standard: Electromagnetic compatibility - Requirements and tests

1) "Medical Electrical Equipment needs special precautions regarding EMC and needs to be installed and put into service according to the EMC information provided in the Accompanying Documents" (the following tables).

2) "Portable and Mobile RF Communications Equipment can affect Medical Electrical Equipment."

3) "The equipment or system should not be used adjacent to or stacked with other equipment and that if adjacent or stacked use is necessary, the equipment or system should be observed to verify normal operation in the configuration in which it is used." The following tables provide information regarding the EMC characteristics of this Medical Electrical Equipment.

\* The compliance levels of immunity referred to in tables 202 and 204 have not been arrived at by testing, but by declaration on the basis that the Thoracic suction pump contains no electronic components and is inherently immune to the specified levels of electromagnetic disturbance. The performance of all functions of the Thoracic suction pump are considered essential performance for the purpose of electromagnetic immunity.

**Table 201 — Guidance and manufacturer’s declaration - electromagnetic emissions - all equipment and systems**

<b>Guidance and manufacturer’s declaration - electromagnetic emissions</b>		
The Thoracic suction pump is intended for use in the electromagnetic environment specified below. The customer or user of the Thoracic suction pump should assure that it is used in such an environment.		
<b>Emissions Test</b>	<b>Compliance</b>	<b>Electromagnetic environment - guidance</b>
Harmonic Emissions IEC 61000-3-2	Class A	The Thoracic suction pump is suitable for use in all establishments, including domestic establishments and those directly connected to the public low-voltage power supply network that supplies buildings used for domestic purposes.
Voltage fluctuations / flicker emissions IEC 61000-3-3	Complies	
RF emissions CSIPR 14-1	Complies	The Thoracic suction pump is not suitable for interconnection with other equipment.

**Table 202 — Guidance and manufacturer’s declaration - electromagnetic immunity  
- for all equipment and systems**

<b>Guidance and manufacturer’s declaration - electromagnetic immunity</b>			
The Thoracic suction pump is intended for use in the electromagnetic environment specified below. The customer or user of the Thoracic suction pump should assure that it is used in such an environment.			
<b>Immunity Test</b>	<b>IEC 61000 test level</b>	<b>Compliance level (not tested) *</b>	<b>Electromagnetic environment - guidance</b>
Electrostatic discharge (ESD) IEC 61000-3-4	±6 kV contact ±8 kV air	±6 kV contact ±8 kV air	Floors should be wood, concrete or ceramic tile. If floors are covered with synthetic material, the relative humidity should be at least 30%.
Electrical fast transient/burst IEC 61000-4-4	±2 kV for power supply lines ±1 kV for input/output lines	±2 kV for power supply lines ±1 kV for input/output lines	Mains power quality should be that of a typical commercial or hospital environment.
Surge IEC 61000-4-5	±1 kV line(s) to line(s) ±2 kV line(s) to earth	±1 kV line(s) to line(s) ±2 kV line(s) to earth	Mains power quality should be that of a typical commercial or hospital environment.
Voltage dips, short interruptions and voltage variations on power supply input lines IEC 61000-4-11	<5 % $U_T$ (>95% dip in $U_T$ for 0.5 cycle) 40 % $U_T$ (60% dip in $U_T$ for 5 cycles) 70 % $U_T$ (30% dip in $U_T$ for 25 cycles) <5 % $U_T$ (>95% dip in $U_T$ for 5 sec)	<5 % $U_T$ (>95% dip in $U_T$ for 0.5 cycle) 40 % $U_T$ (60% dip in $U_T$ for 5 cycles) 70 % $U_T$ (30% dip in $U_T$ for 25 cycles) <5 % $U_T$ (>95% dip in $U_T$ for 5 sec)	Mains power quality should be that of a typical commercial or hospital environment. The unit shut off during the >95% dip for 5 sec disturbance. If the user of the Thoracic suction pump requires continued operation during power mains interruptions, it is recommended that the Thoracic suction pump be powered from an uninterruptible power supply or battery.
Power frequency (50/60Hz) magnetic field IEC 61000-4-8	3 A/m	3 A/m	Power frequency magnetic fields should be at levels characteristic of a typical location in a typical commercial or hospital environment.

**Table 204 — Guidance and manufacturer’s declaration - electromagnetic immunity - for equipment and systems that are NOT life-supporting.**

<b>Guidance and manufacturer’s declaration - electromagnetic immunity</b>			
The Thoracic suction pump is intended for use in the electromagnetic environment specified below. The customer or user of the Thoracic suction pump should assure that it is used in such an environment.			
<b>Immunity Test</b>	<b>IEC 61000 test level</b>	<b>Compliance level (not tested) *</b>	<b>Electromagnetic environment - guidance</b>
Conducted RF IEC 61000-4-6	3 Vrms 150 kHz to 80 MHz	3 Vrms	Portable and mobile communications equipment should be used no closer to any part of the Thoracic suction pump, including cables, than the recommended separation distance calculated from the equation applicable to the frequency of the transmitter.  Recommended separation distance $d = [3.5/V_1]\sqrt{P}$
Radiated RF IEC 61000-4-3	3 V/m 80MHz to 2.5 GHz	3 V/m	$d = [3.5/E_1]\sqrt{P}$ 80 MHz to 800MHz  $d = [7/E_1]\sqrt{P}$ 800 MHz to 2.5GHz  where P is the maximum output power rating of the transmitter in watts (W) according to the transmitter manufacturer and d is the recommended separation distance in metre (m). Field strengths from fixed RF transmitters, as determined by an electromagnetic site survey, should be less than the compliance level in each frequency range. Interference may occur in the vicinity of equipment marked with the following symbol  



## Warranty

BMDi TUTA Healthcare Medical Equipment Pty Limited ("BMDi TUTA Healthcare") warrants that this product is free from defects in workmanship and materials for a period of 12 months (3 months for batteries) from the date of shipment by BMDi TUTA Healthcare or its authorised agent to the purchaser. Subject to the conditions of this warranty, if the product fails to operate for any reason within the warranty period and the product is returned to the place of purchase at the purchaser's expense, BMDi TUTA Healthcare will repair or replace the product free of charge.

If a valid warranty claim is made within 30 days from the date of shipment, then BMDi TUTA Healthcare will also reimburse the purchaser for reasonable freight costs in returning the product to the place of purchase.

## Conditions of Warranty

1. The product must be returned to the place of purchase with proof of purchase.
2. This warranty is only available to the original purchaser of the product.
3. The product must not have had its serial number removed, defaced or changed, its casing opened, its power supply altered or have been tampered with in any other way.
4. This warranty does not cover :
  - inadequate or incorrect site preparation;
  - improper installation;
  - connection to the wrong voltage;
  - failure of the product due to misuse;
  - the use or operation of the product outside of the physical, electrical or environmental specifications of the product;
  - use in a manner or environment in which the product is not designed to be used;
  - improper adjustment, calibration or operation by the purchaser;
  - the use of accessories including consumables, hardware or software which were not manufactured or approved in writing by BMDi TUTA Healthcare;

- any modifications of the product which were not authorised in writing by BMDi TUTA Healthcare;
  - any contamination or leakages caused or induced by the purchaser; and
  - inadequate or improper maintenance of the product.
5. This warranty does not cover normal wear and tear.
  6. BMDi TUTA Healthcare will not be responsible for damage or loss caused during shipping.
  7. In Australia, apart from any warranties implied by the Trade Practices Act 1974 all other warranties expressed or implied and whether arising by virtue of statute or otherwise are hereby excluded.
  8. Outside Australia, all other warranties expressed or implied and whether arising by virtue of statute or otherwise (including any warranties implied by the Vienna Convention) are hereby excluded.
  9. BMDi TUTA Healthcare' obligations under this warranty are limited to the repair or replacement of the product, within the terms of this warranty and the total liability of BMDi TUTA Healthcare for loss or damage of every kind whether arising pursuant to the terms of the sale of the product or otherwise in connection with the product is limited to the amount paid by the purchaser to BMDi TUTA Healthcare for the product.
  10. Apart from any liability imposed by Part VA of the Trade Practices Act, BMDi TUTA Healthcare accepts no other liability for any loss or damage occasioned (including consequential loss or damages) in any way as a result of the use of the product.
  11. The warranty does not extend to cover damage to the following parts as they are inherently prone to wear :
    - motor brushes
  12. This warranty does not extend to cover corrosion due to any cause nor to any damage to painted or anodised surfaces.
  13. BMDi TUTA Healthcare will give the purchaser the benefit of any manufacturer's warranty in respect of any components in the product which were not manufactured by BMDi TUTA Healthcare, if such a manufacturer's warranty is available.

